

**GEN-2T Back of Cab CNG System
For Medium and Heavy-Duty Vehicles**

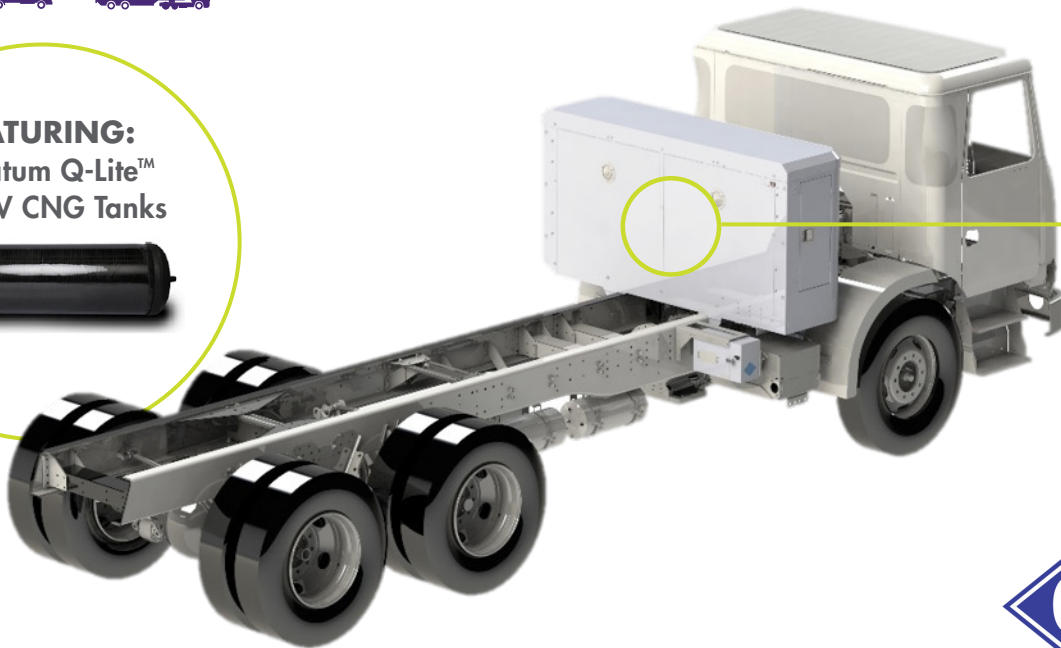

FEATURING:
Quatum Q-Lite™
Type IV CNG Tanks

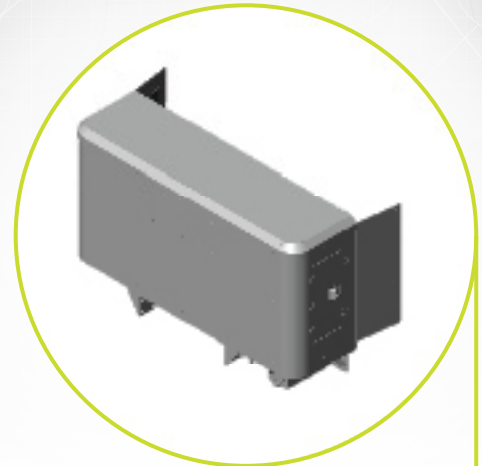

MAJOR FEATURES INCLUDE:

DESCRIPTION	UNITS	GEN-2T BOC SYSTEM
Range	Miles	200-250
Fuel Capacity	DGE	58
Dimensions (W x H x D)	Inches	90.5 x 46 x 25.25
Fuel Module	-	Separate MA20
Total Frame Weight (w/o Tanks)	Lbs	775
Weight of Tanks (Qty. 2-21"x86" Neck Mount)	Lbs	370 (185/tank)
Total System Weight (Empty)	Lbs	1145
Total System Weight (Full)	Lbs	1467

All units are tested and serialized for warranty, tracking and servicing functionality.

MAINSTAY
FUEL TECHNOLOGIES



MAINSTAYFUELTECH.COM